

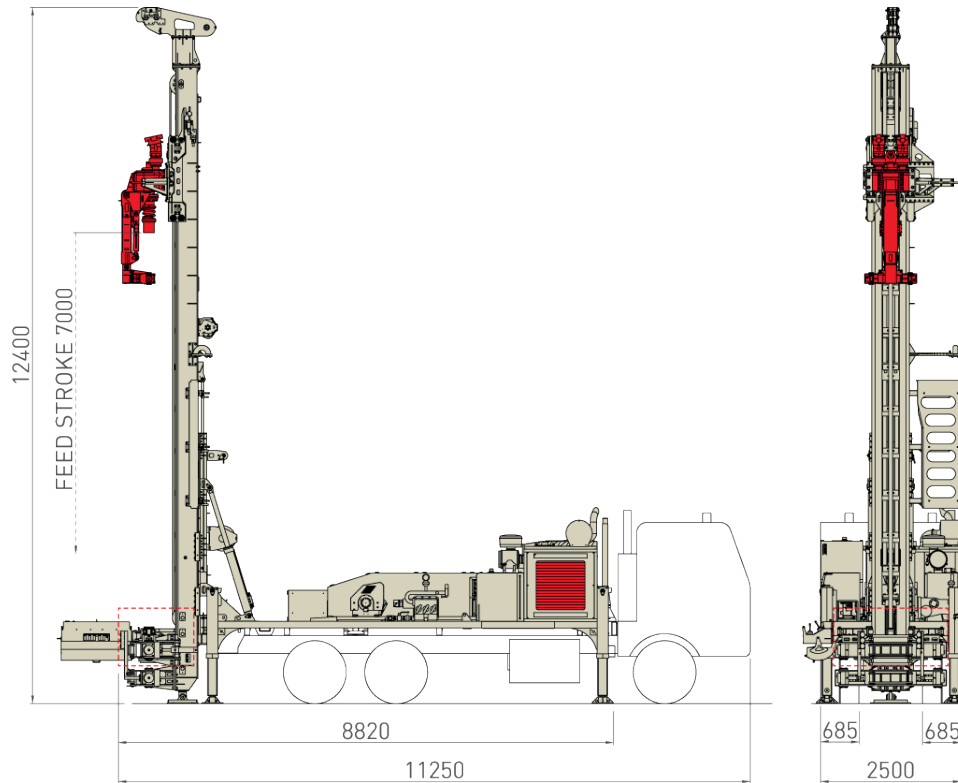

MC-T 20



m.s. i.s.

Camion (assi) Truck (axles)	-		(6x6 - 8x4 - 8x6) 3/4
Potenza Motore Engine Power	kW	HP	205 - 245 278 - 333
Livello Emissioni Emission Level	-		Step 3A/Tier3 - Step 5/Tier 4f (HT line)
Corsa Mast Mast Feed Stroke	mm	ft	7.000 22.9
Forza di Spinta Feed Force	daN	lbs	12.000 26,977
Forza di Tiro Retract Force	daN	lbs	20.000 44,962
Coppia Rotary Rotary Torque Range	daNm	lb*ft	2.300 - 3.750 16,963 - 27,658
Giri Rotary Rotary Speed Range		rpm	40 - 180
Serraggio Morse Clamp Range	mm	in	45 - 520 1.8 - 20.4
Argano Winch	kg	lbs	2.000 - 5.700 4,400 - 12,600
Peso Perforatrice Rig Weight	kg	lbs	13.000 - 18.000 28,600 - 39,700



This is a simplified data sheet that does not show all possible rig configurations. For further information [click here](#).